



Scientific and Technical Center of Unified Power System



European User's Group Meeting
October 6–7, 2014 Technical University of Denmark

Accuracy estimation of power system mathematical model and its individual elements in the RTDS Simulator using a Laboratory of Electric Power Systems Physical Modeling equipment

Zelenin Aleksandr
mailto: zelenin@ntcees.ru
Engineer, Department of Electric Power Systems

Introduction: Unified Power System of Russia

Unified Power System of Russia (UPS of Russia) has a number of features. One of these features is the presence of long lines between concentrated power subsystems with a relatively **small transmission capacity**.

Therefore, low-frequency oscillations often are observed in UPS of Russia. The increment of such oscillations can lead to loss stability and / or other major accidents.

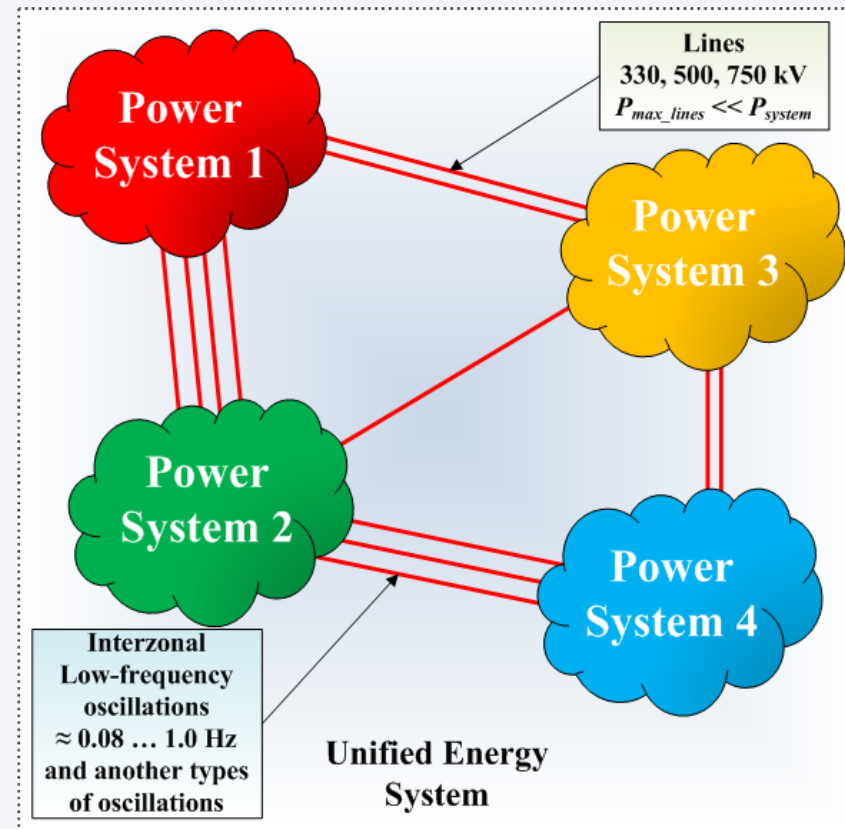

Introduction:

AVRs and UPS of Russia

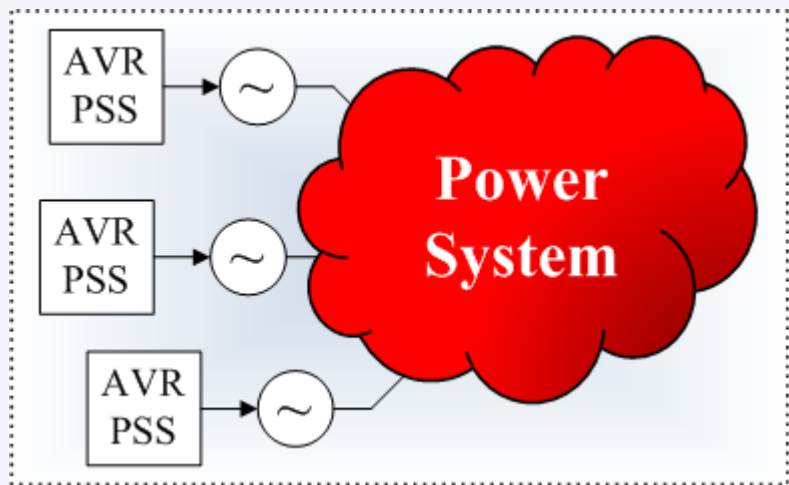

In order to prevent the appearance and / or the increment of low-frequency oscillations in the UPS of Russia are being taken various measures. One such measure is the use of **automatic voltage regulators and power system stabilizers**.

However, the experience of using various types of AVR-devices (or AVR+PSS-devices) from different manufacturers showed, that not all of them can provide oscillation damping of a **wide spectrum of frequencies**, which exist in some parts in UPS of Russia. In addition, a some of them do not include a number of functional algorithms, the need for which is dictated by specific features UPS of Russia.

Introduction:

Test scheme for AVR studies

To reduce the risk of accidents, which can occur because of incorrect work of the AVR-devices, Russian System Operator gave the task to «STC UPS» to create the document (Standard), which includes the basic requirements for AVR and AVR testing procedure. AVR test procedure involves using of specialized bench – Test scheme. Test scheme was created on the basis of a power system physical model and includes real low-power equipment.



Machine room and the control room of the physical model



Introduction: test methodology

To perform a test procedure, AVR should be connected to generator of the Test scheme. AVR settings are chosen by AVR-developers by their procedure, which is used in real power systems (for example: by setpoint changing and etc.).

Test procedure perform out in a variety of circuit-operation conditions and the implementation of various perturbations:

1. small perturbations;
2. large perturbations, which are accompanied by tripping lines, automatic reclosing, breaker failure protection;
3. perturbations, which are causing the change in frequency;
4. other perturbations to verify some functions AVR (OEL, UEL, et al.).

More than 10 different AVR full scale specimens. Further improvement of the Standard and using RTDS Simulator are considered.

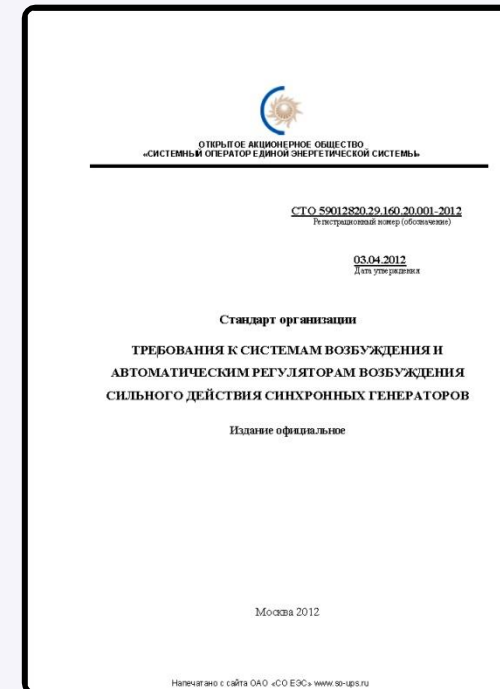

Introduction: the task of creating a mathematical model

Mathematical model of the Test scheme was implemented in RTDS. Full scale specimen AVR was connected to RTDS. Standard test program was performed. Next task was to compare RTDS results and physical model results.

Test scheme includes:

6 generators, 5 asynchronous motors, 5 shunts, 8 transformers, 7 models of power lines (RL-chain), capacitor banks, excitation systems, device AVR, speed controllers, disturbance simulation automatic, etc.

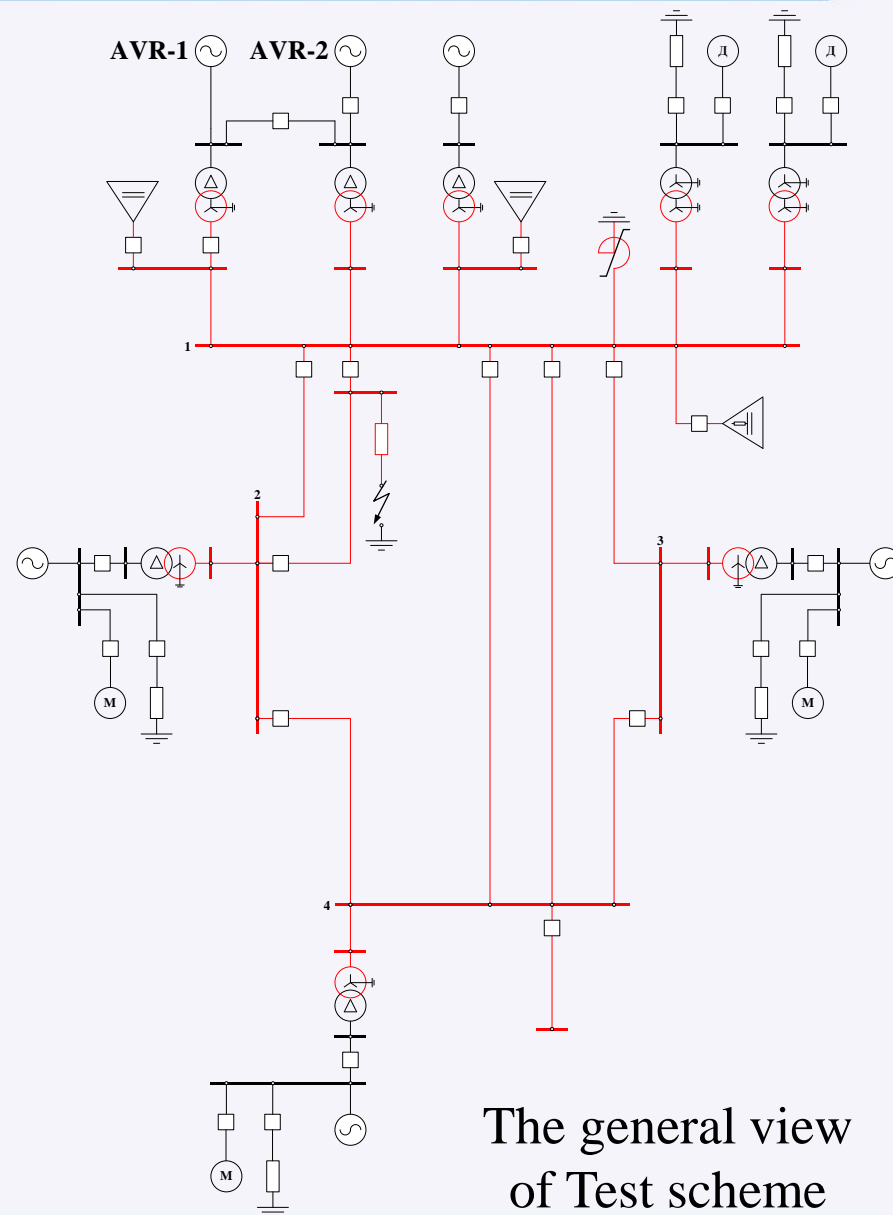

The general view of Test scheme

Introduction: the task of creating a mathematical model: external AVR connection to Test-scheme

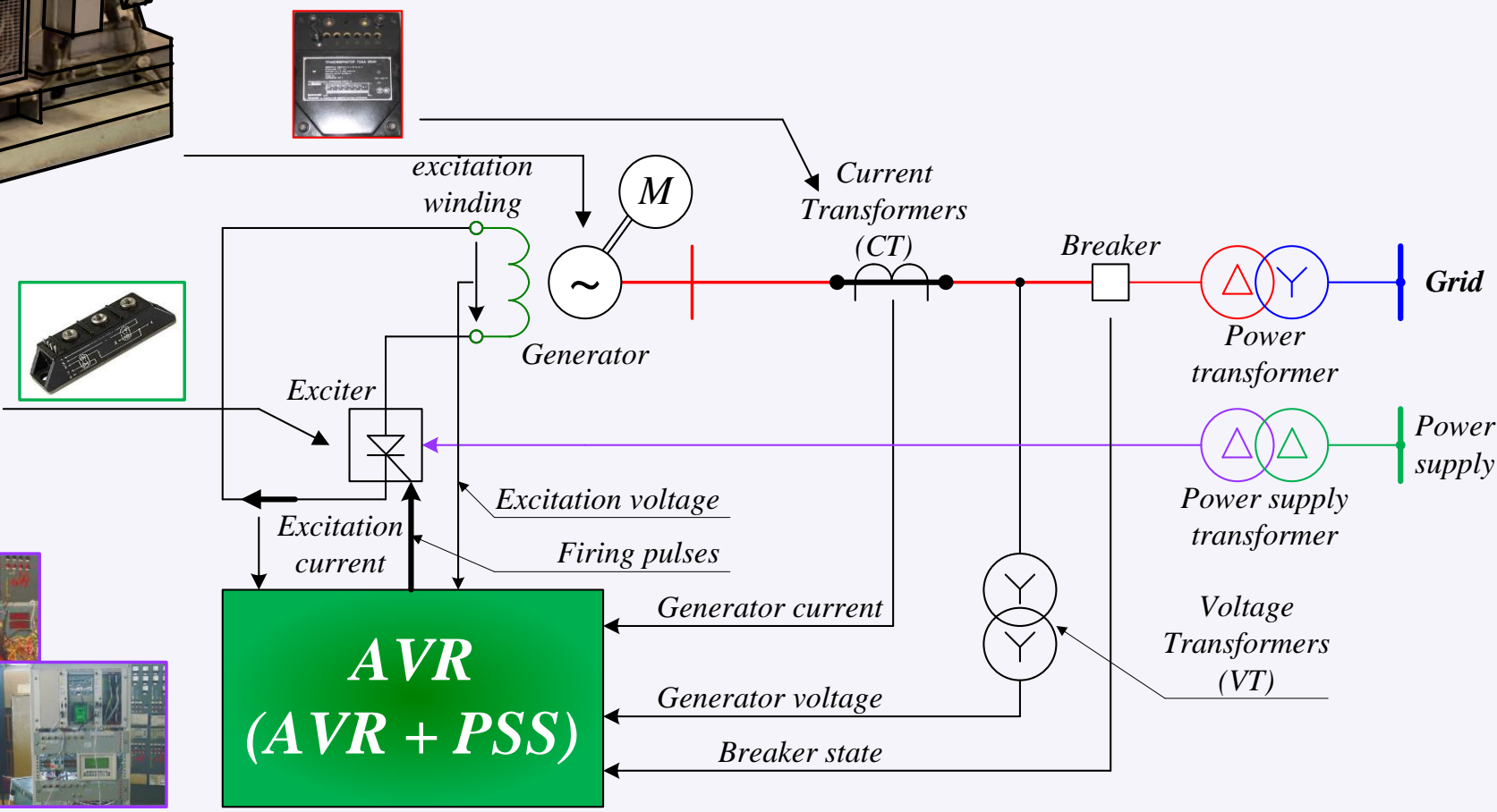
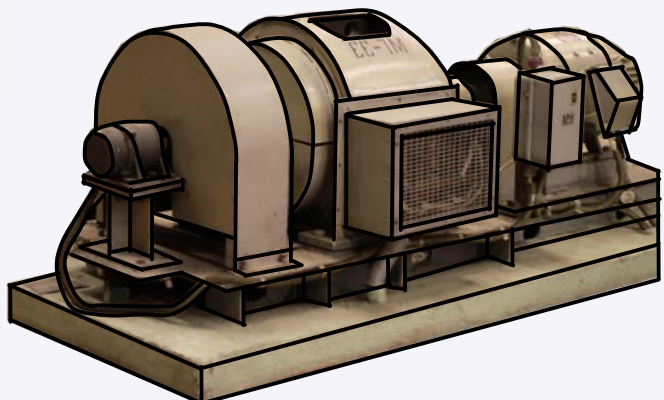

Generalized scheme of connection of AVR

Chapter I: study of the main properties of the Test scheme (I)

It is hard to pass testing procedure for AVR-device by some reasons. Experiments in all different scheme-operation conditions (only 15 modes) must be carried out with the same AVR setting. However, various scheme-operation conditions have different resonant frequencies (0.2 to 3 Hz and up). And various modes have different stability areas.

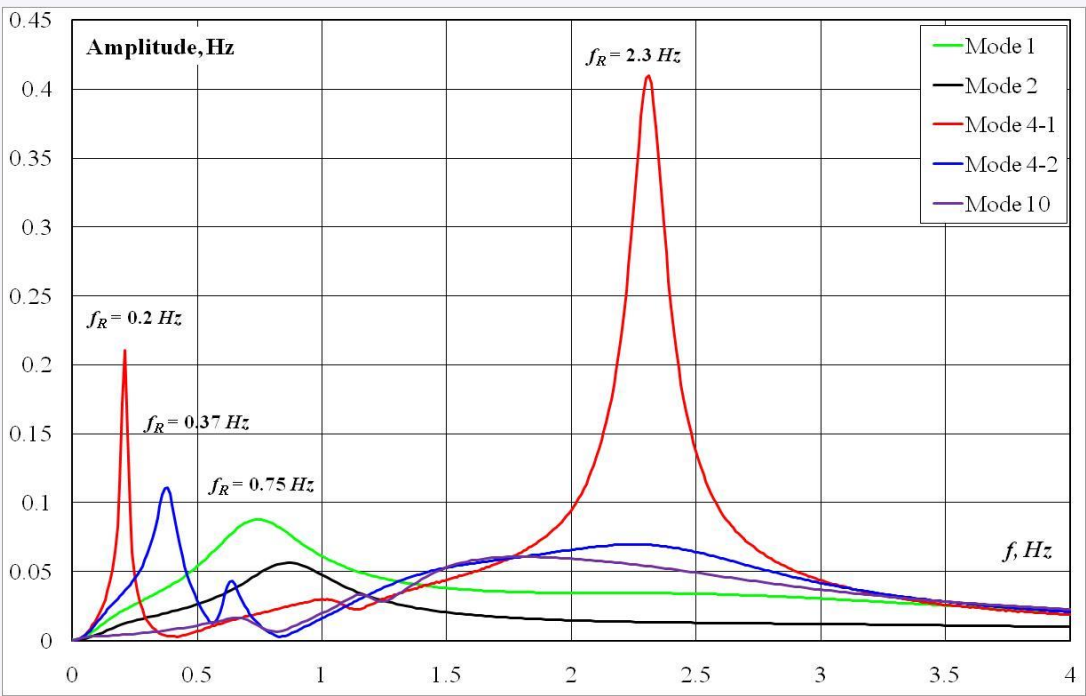

General view of the *calculated* spectrum of the oscillation frequencies in different electrical modes
 * Obtained using the mathematical model after the first phase of verification

Chapter I: study of the main properties of the Test-scheme (II)

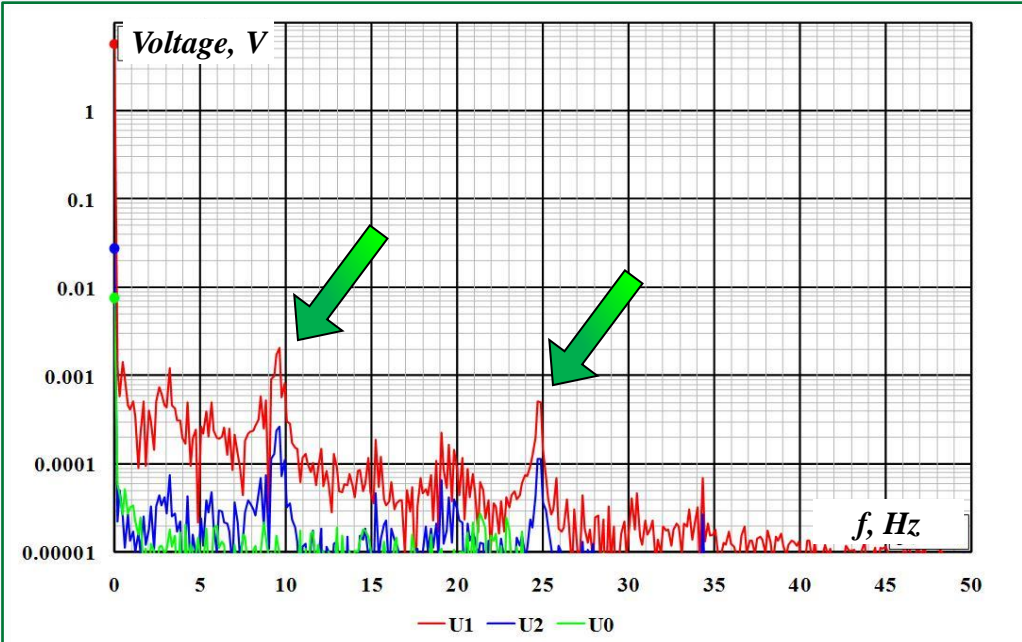

FFT of RMS generator voltage (positive, negative and zero sequences)

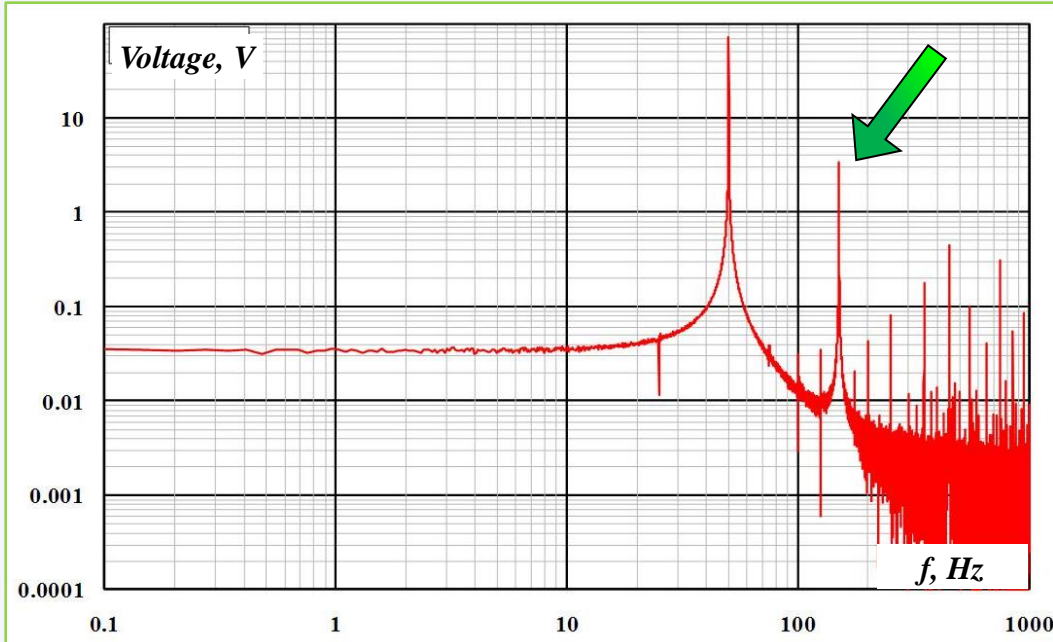

FFT of sinusoidal generator voltage (phase A)

Signals in physical model can include high frequency harmonics and some other distortions. For example, the third harmonic (**4.5%** of the base), the RMS stator voltage includes **16.67** and **25** Hz components. In addition, signals are including are negative and zero sequence (whose amplitude does not exceed 2% of the amplitude of direct sequence).

The task was to implement distorted signals in RTDS.



Chapter I: Sources of error

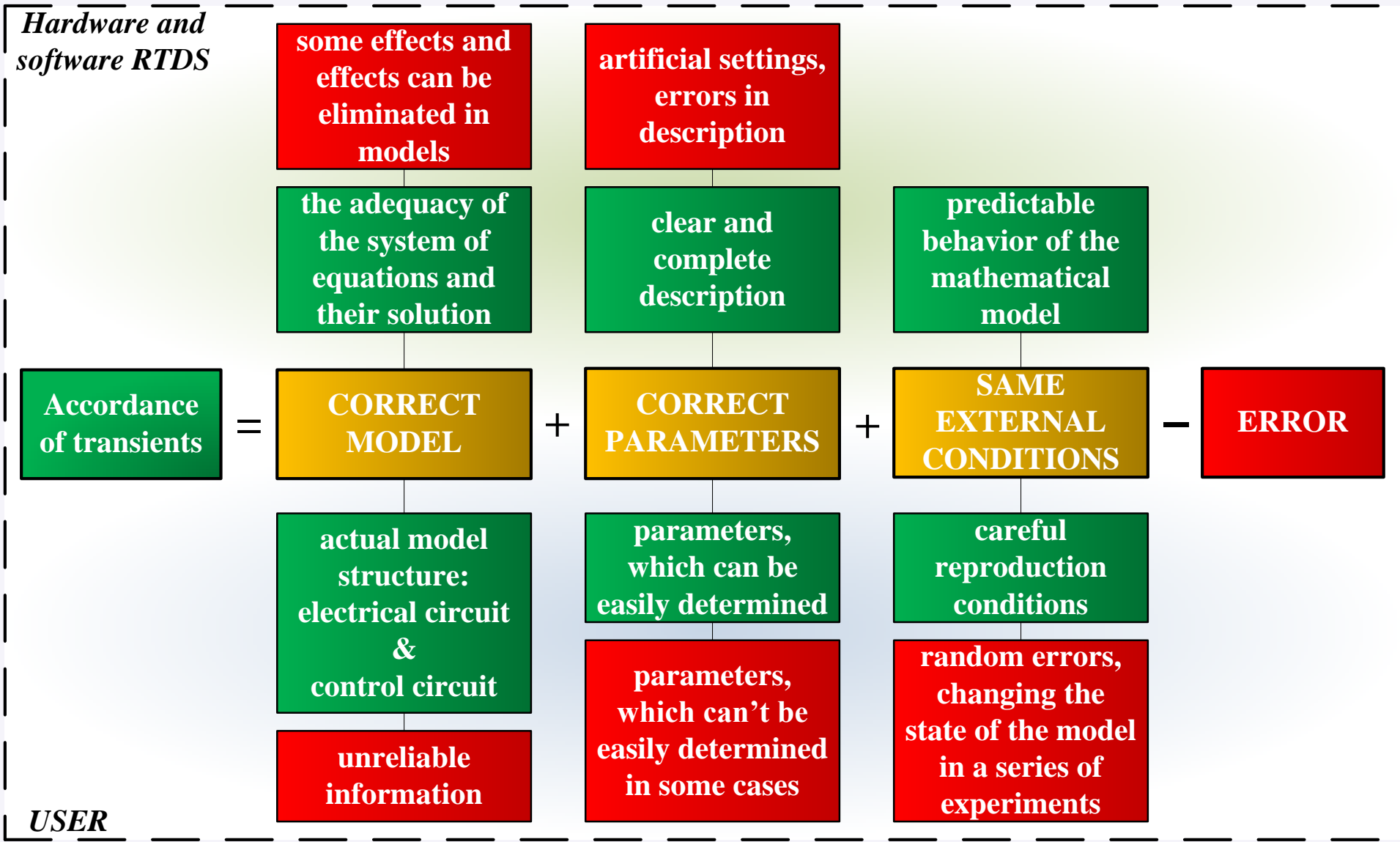



Chapter II: preparation parameters of the model elements (power elements)

Preparation elements parameters of the primary circuit:

- **lines and static load** (short circuit experience. Note: model line test circuit – coil);
- **capacitor banks** (capacitance meter);
- **induction motors** (induction motors test circuit – industrial motors manufactured in the 1950's. their equivalent circuit parameters were calculated on the basis of catalog data, inertial constant was determined on the basis of experience of direct start);
- **transformers**
 - open circuit test – the magnetization characteristic, active and reactive load losses;
 - short-circuit test – the winding resistance and leakage reactance.
- **synchronous generators**
 - open circuit test – the magnetization characteristic;
 - short-circuit test – X_d ;
 - experiment to determine X_q (by the vector diagram of the generator);
 - experiment: excitation of the generator from a DC voltage source, with open stator – T'_{d0} ;
 - experiment: excitation of the generator from a DC voltage source with a closed stator – T'_d ;
 - experiment a sudden three-phase short-circuit on the tires generator: $X'_d, X''_d, T'_d, T'_{d0}$;
 - experiment to determine X''_d, X''_q (slow rotor rotation of the generator);
 - experiments to determine the H_J have not clear results. Inertial constants were determined indirectly by analyzing the waveform oscillation transients.

Chapter II: preparation parameters of the model elements (control elements)



Control elements of the Test scheme was also modeled in RTDS. To ensure the identity of transients it is necessary to adequately reproduce the AVR work of other generators (look G-1_2, G2, G3, G4 in scheme). For this special method was used (look presentation «*Obtaining frequency responses of AVR and PSS using RTDS Simulator*»). The experimental frequency characteristics were approximated by solving a system of linear equations.

On the solution of linear equations was imposed the following conditions:

- set the number of roots (poles) of the transfer function;
- requires that coefficients of polynomials has only real part.

Nonlinear characteristics and functions were modeled based on the description and the circuitry to implement them.

Chapter II: scheme realization problems

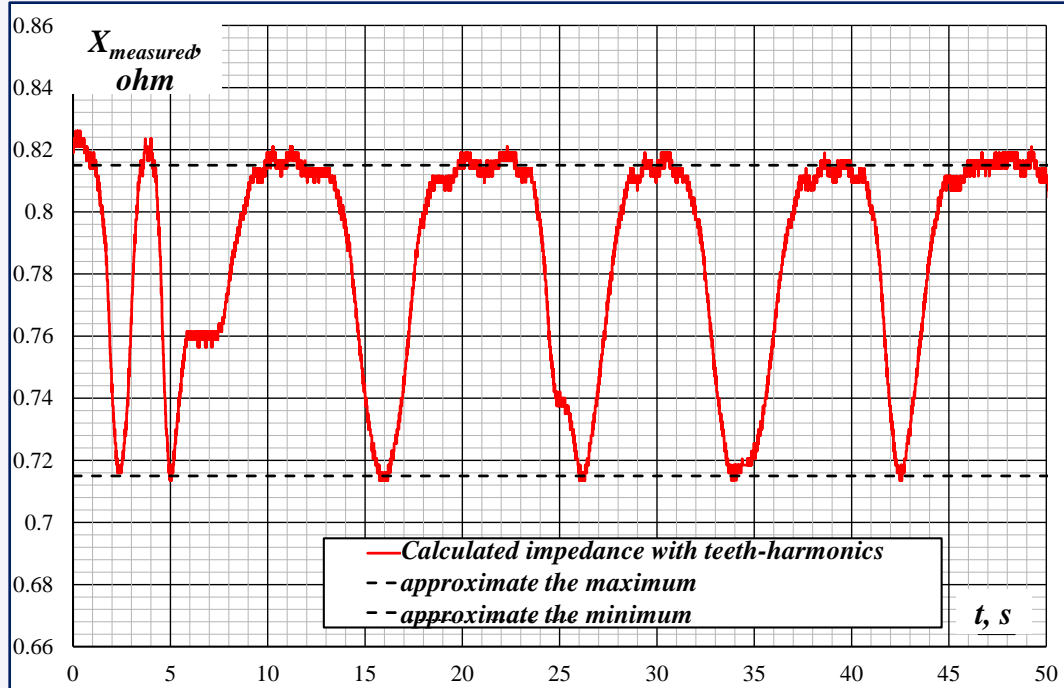
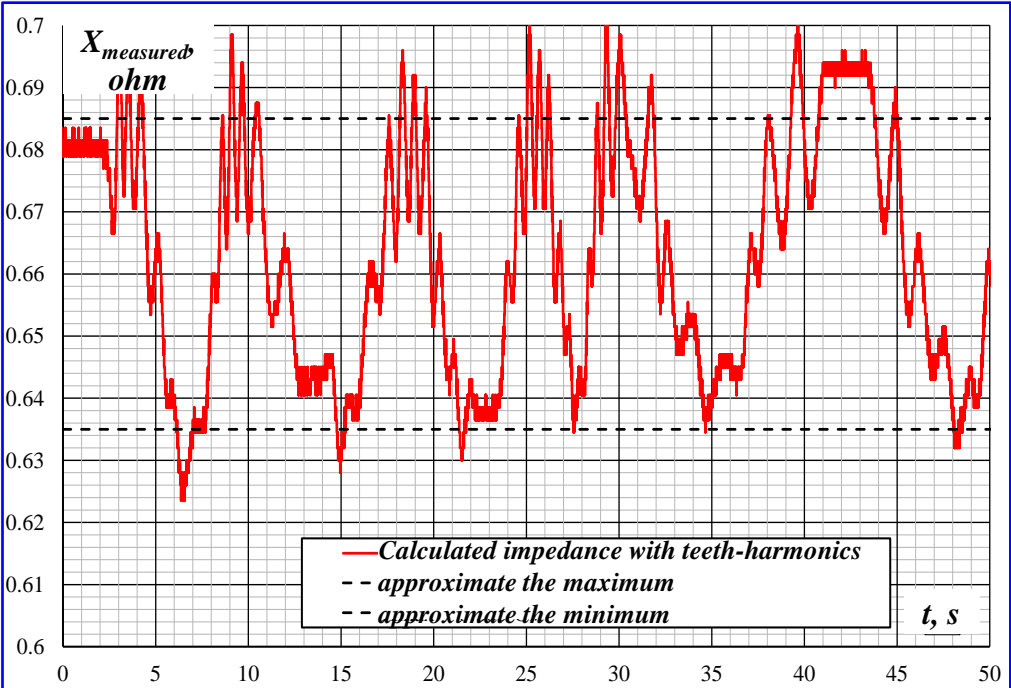

Slow rotor rotation test.

Harmonics from implicit-pole and salient pole generator stator teeth

To represent the tooth harmonics need generator MMF-model. Tooth harmonics was not implemented. Unfortunately, this neglect is getting work for measuring part of certified AVR-device much easier.

Distortions of signals was implemented only on output (not on scheme).

Chapter III: comparison of the Test-scheme and its mathematical model in RTDS («small»)

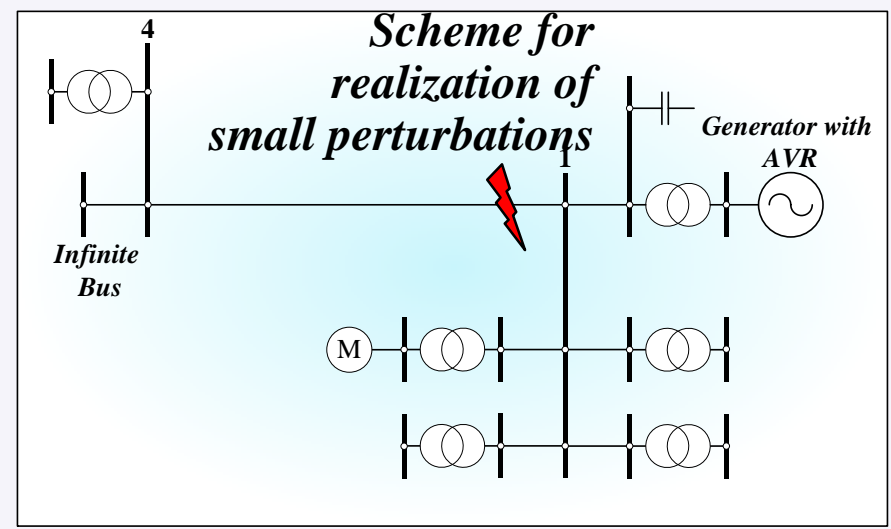
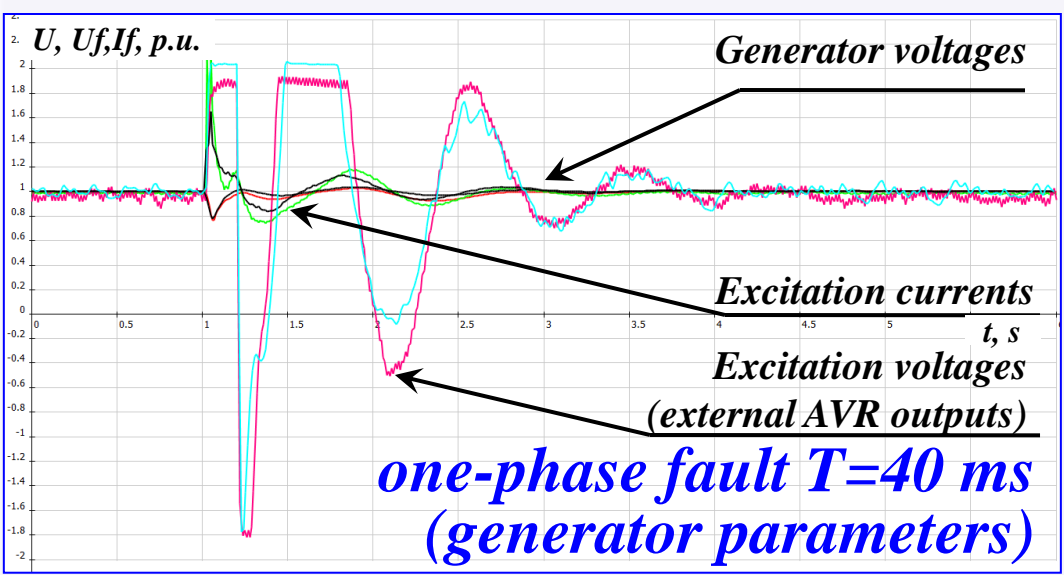
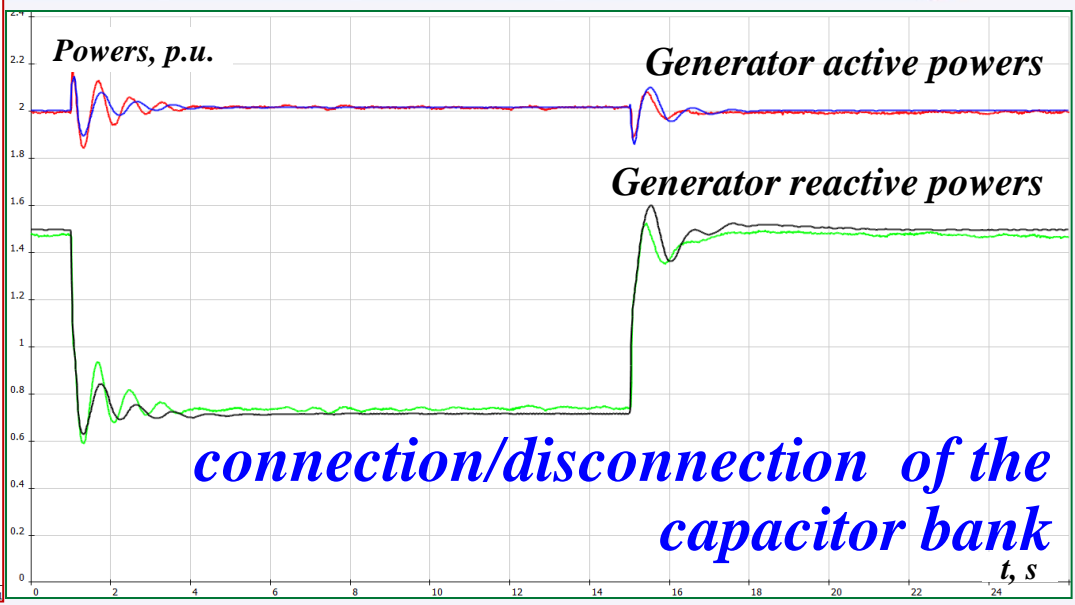
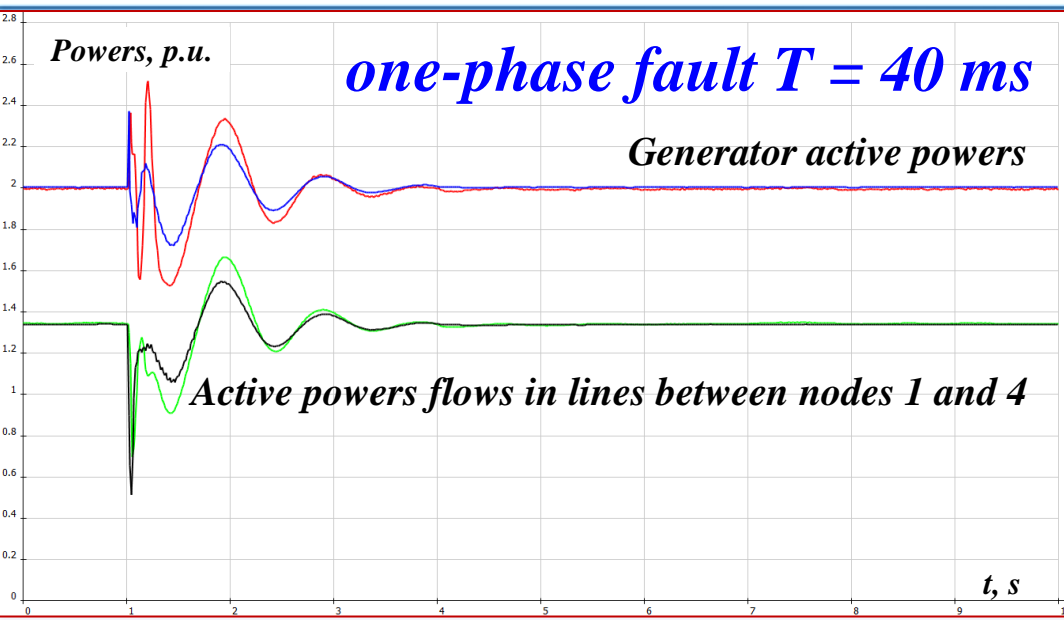

Chapter III: comparison of the Test-scheme and its mathematical model in RTDS («large»)

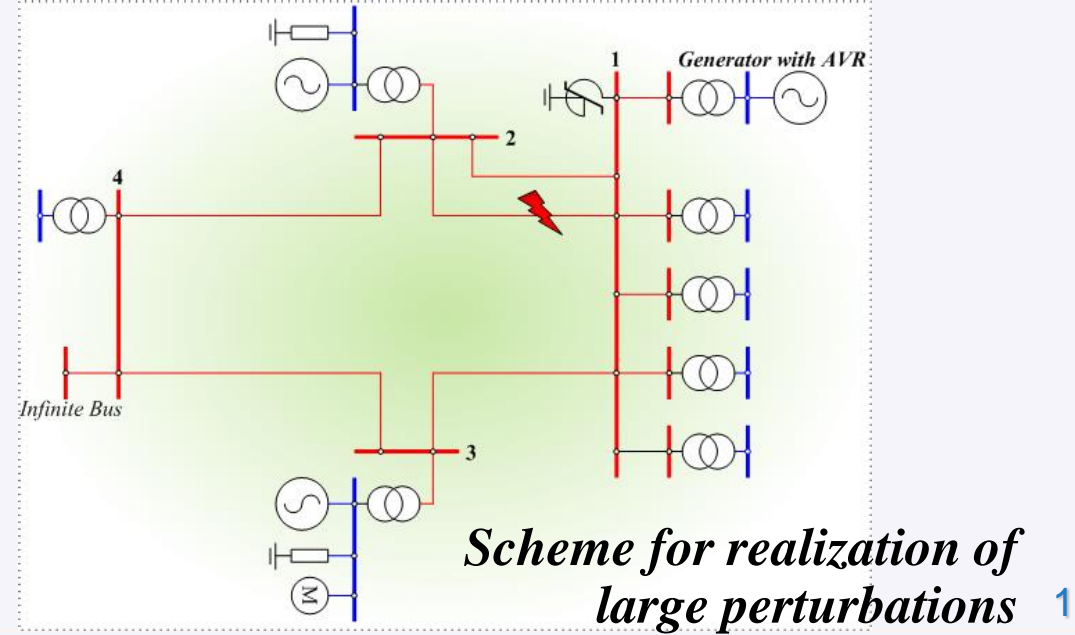
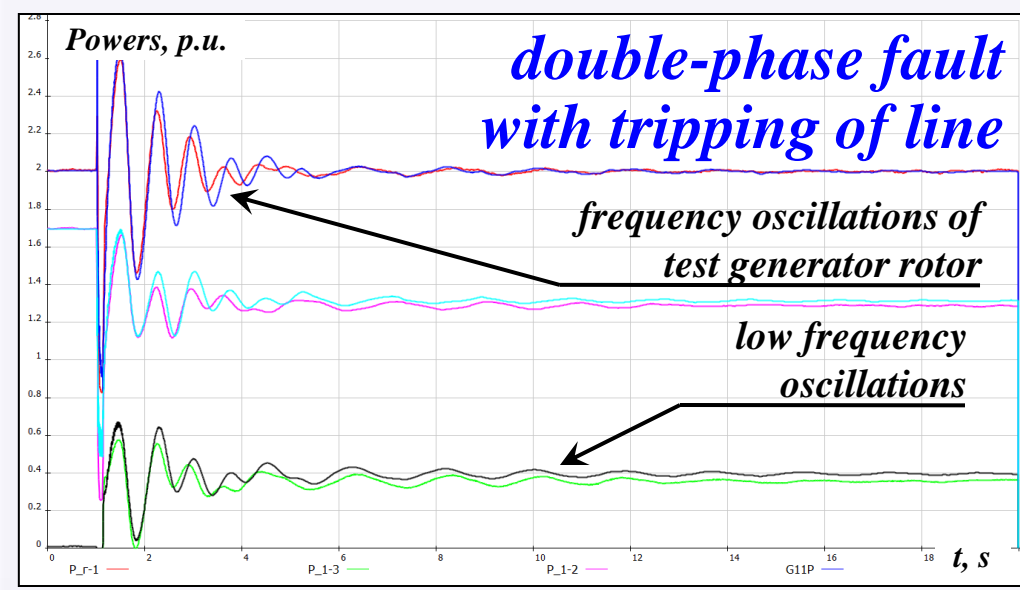
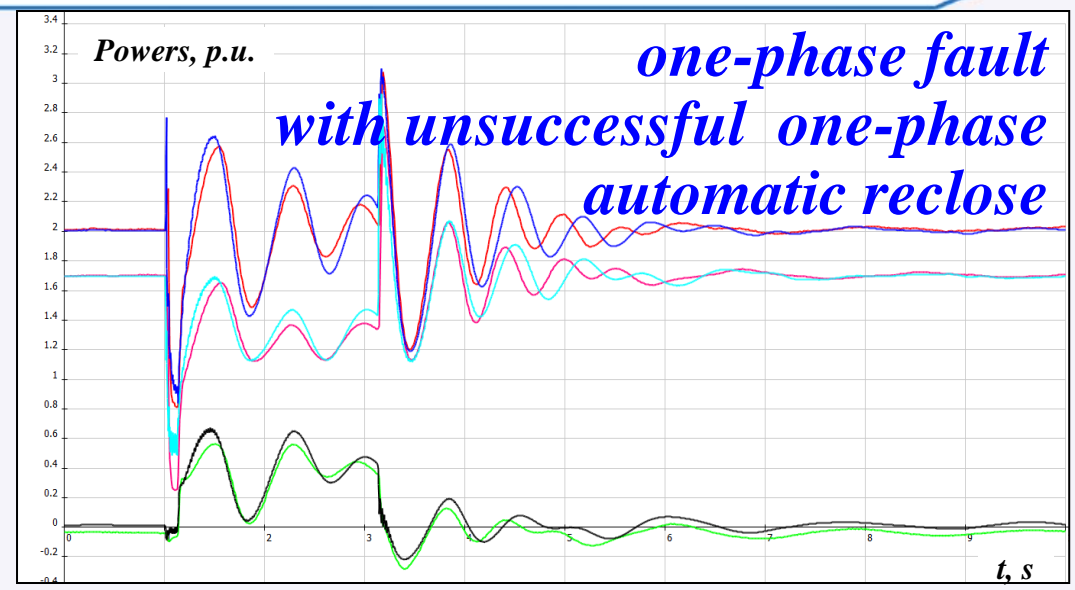
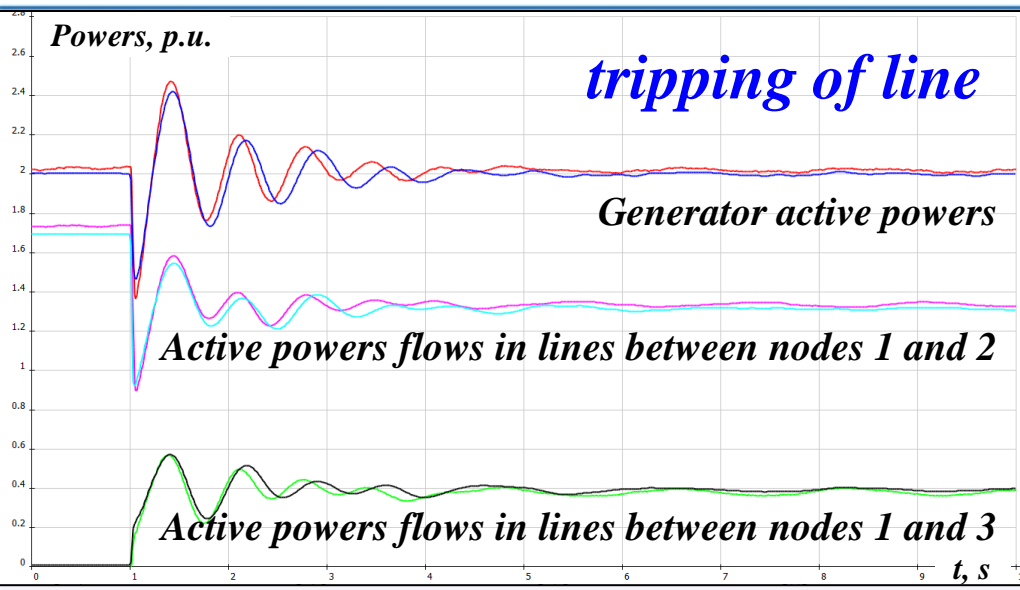

Chapter III: comparison of the Test-scheme and its mathematical model in RTDS

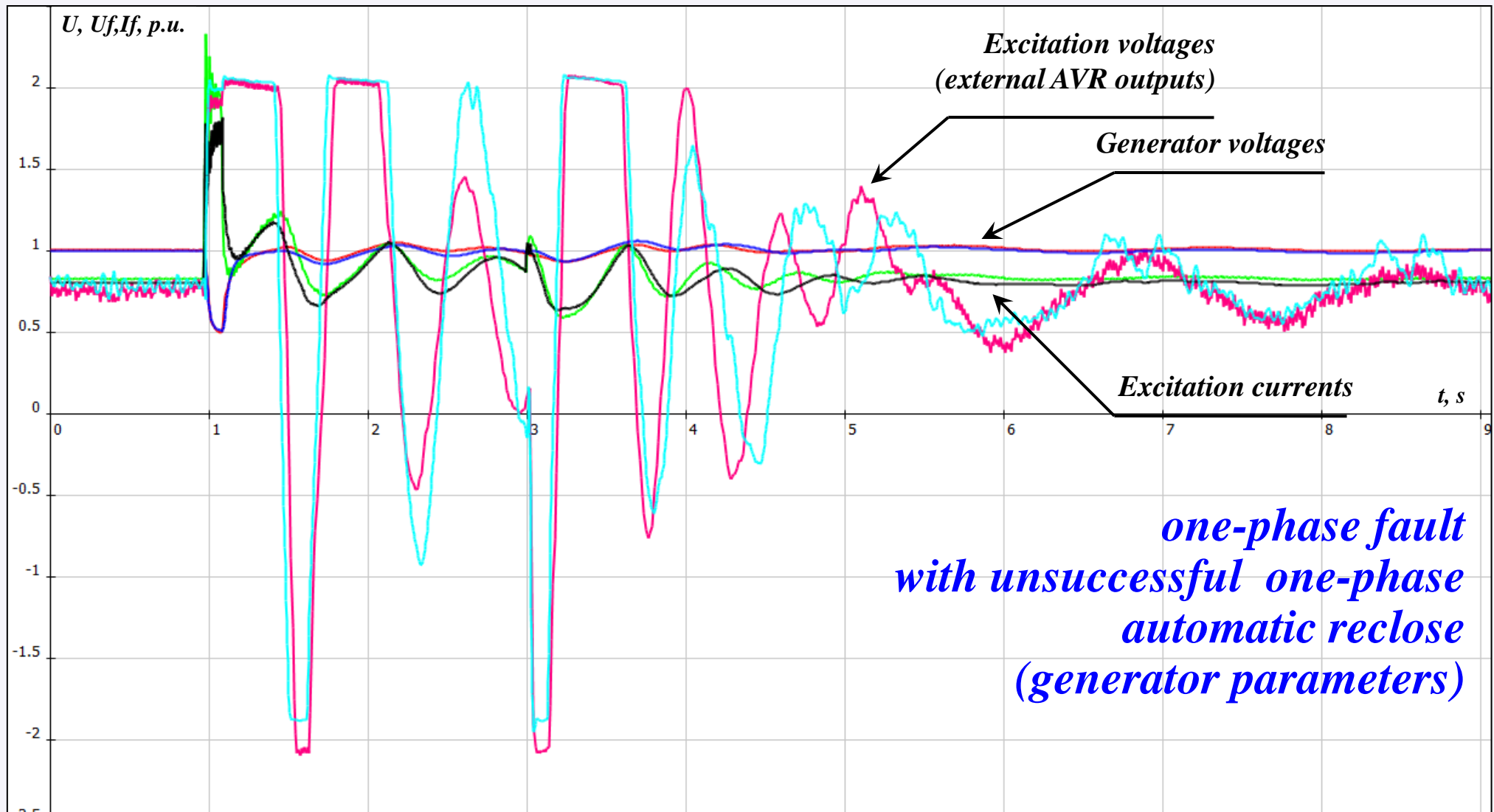

Chapter III: comparison of the Test-scheme and its mathematical model in RTDS («frequency change»)

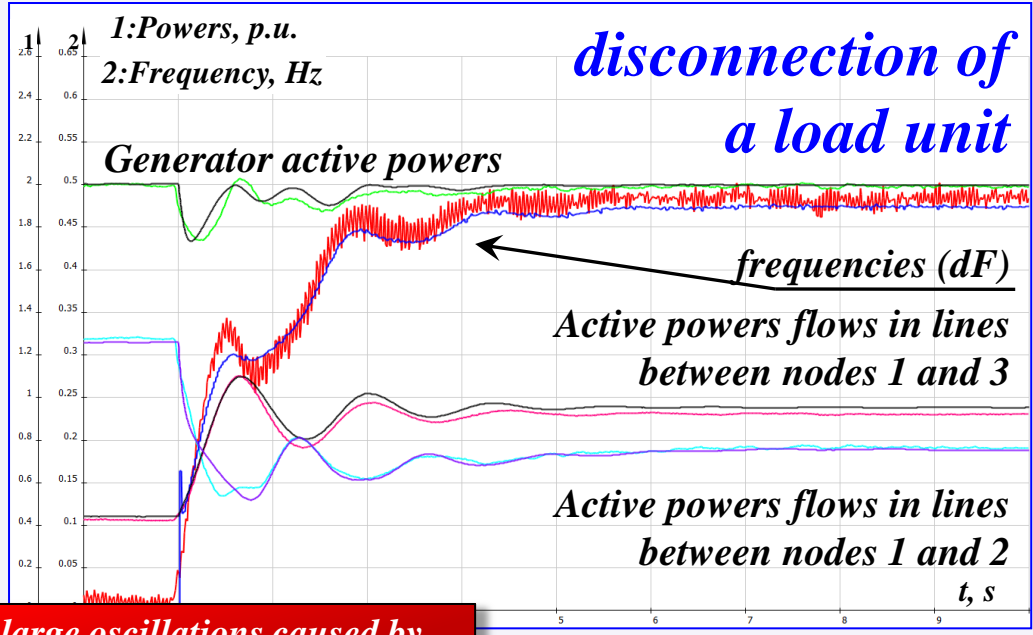
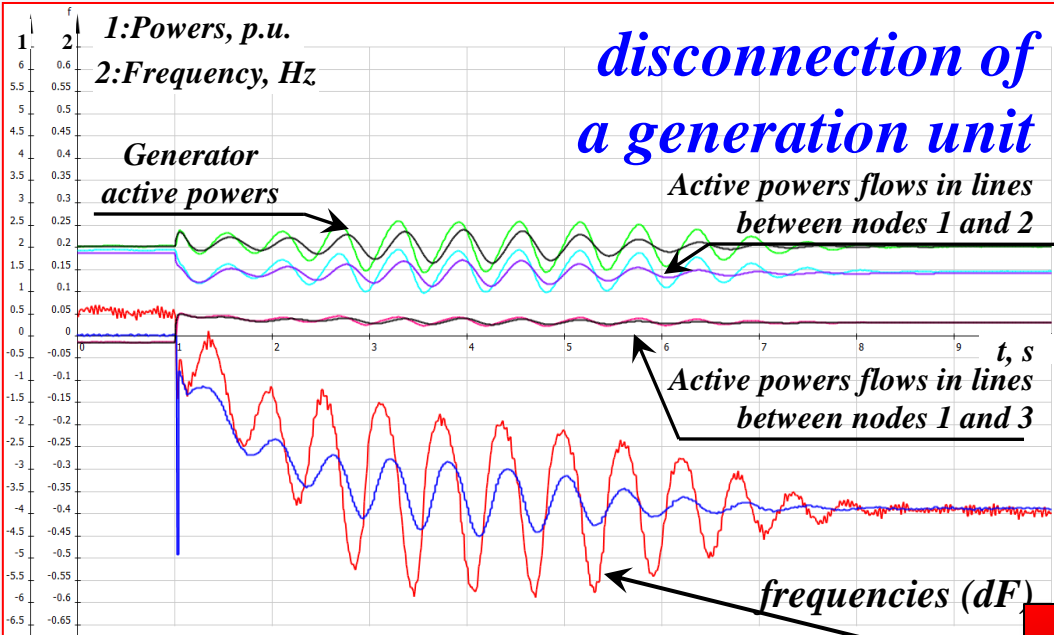

large oscillations caused by incorrect operation of the AVR while frequency is changing

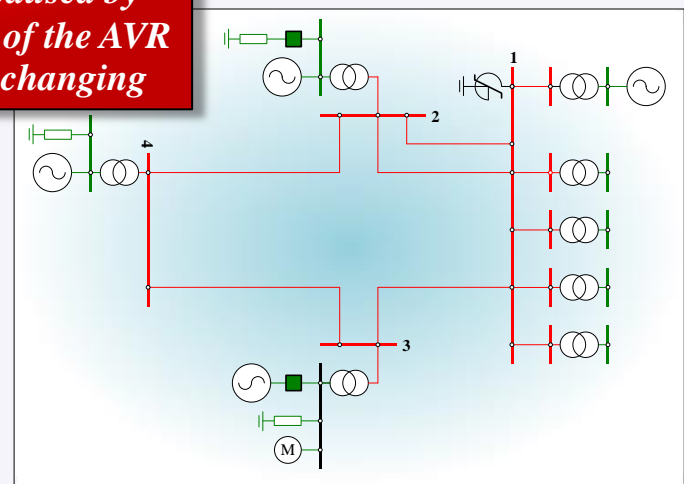
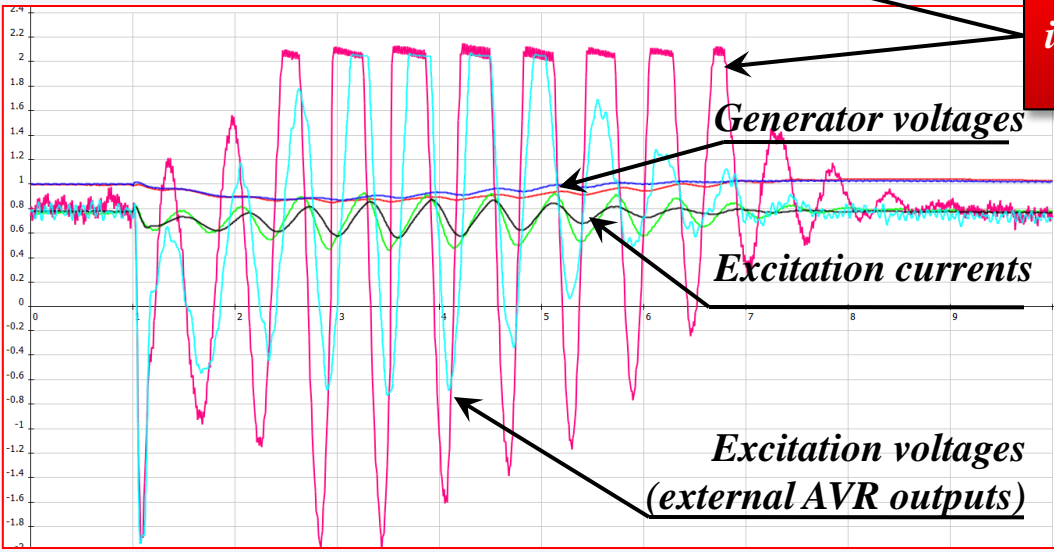

Scheme for experiments with frequency change

Chapter III: comparison of the Test-scheme and its mathematical model in RTDS («excitation current limiter tests»)

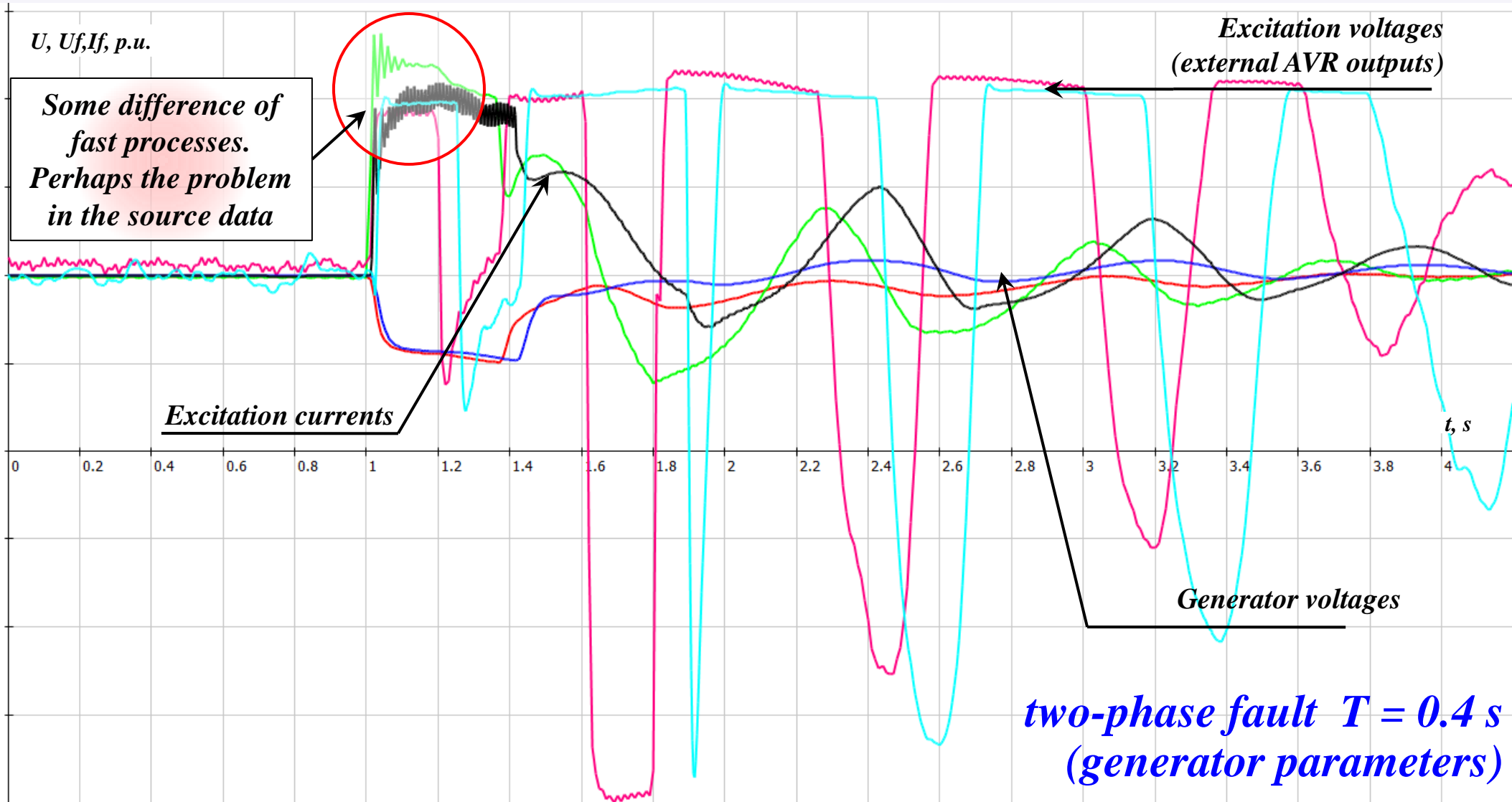



Chapter IV:

conclusion and main results

Today to test the AVR in «STC UPS» is using the **physical model Test scheme**. However, at the moment «STC UPS» is performing a series of studies and consider using of RTDS Simulator.

Mathematical model of Test scheme has been implemented within RTDS. Mathematical model qualitatively reproduces electromechanical transients (in range 0.5-8 Hz) and number of important properties of the Test scheme. **Definitive conclusions about the suitability of the developed mathematical model (in particular in the study of the higher frequency ranges 5-8 ... 25 Hz) will be made in the future.**

Testing a mathematical model showed that in some cases, a more detailed model for the generators is needed (such as MMF-model, which at the moment, as far as I know, is developing by RTDS-Technologies).

I want to say a special thanks for customer support of RTDS for their efficient work.



Contacts

Full name of organization:

Joint Stock Company

«Scientific and Technical Center of Unified Power System»

(JSC «STC UPS»)

Postal address:

194223, Russian Federation, Saint-Petersburg, st. Kurchatov, 1, lit. A

E-mail: ntc@ntcees.ru

Internet: <http://www.ntcees.ru>

Zelenin Aleksandr

E-mail : zelenin@ntcees.ru



Thank you for your attention :)